

Nicrofer[®] 5520 Co – alloy 617

Material Data Sheet No. 4019

January 2005 Edition

Superalloy

QUEENSLAND AGENT:

Isolthermics Australia Pty Ltd

Phone: 07 3245 5561

Fax: 07 3245 4753

Email: info@isolthermics.com.au

Web: www.isolthermics.com.au

A company of
ThyssenKrupp
Steel

ThyssenKrupp VDM



ThyssenKrupp

Nicrofer® 5520 Co – alloy 617

Nicrofer 5520 Co is a nickel-chromium-cobalt-molybdenum alloy with excellent mechanical and creep properties up to 1100 °C (2000 °F) due to solid solution hardening. As a result of its balanced chemical composition the alloy shows outstanding resistance to high temperature corrosion such as oxidation and carburization.

Nicrofer 5520 Co is characterized by:

- very good short-term and long-term mechanical properties up to 1100 °C (2000 °F)
- excellent resistance to oxidation up to 1100 °C (2000 °F)
- excellent resistance to carburization up to 1100 °C (2000 °F)
- good weldability

Designations and standards

Country	Alloy designations	Specification							
		Chemical composition	Tube and pipe		Sheet and plate	Rod and bar	Strip	Wire	Forgings
			seamless	welded					
D DIN EN DIN VdTÜV	W.-Nr. 2.4663 NiCr23Co12Mo	10302 17744 485	485		17750 485	17752 485	17750 [485] ¹⁾	17753	485
F AFNOR									
UK BS									
USA ASTM ASME SAE AMS	UNS N06617		B 167	B 546	B 168 SB-168 5888, 5889	B 166 SB-166 5887	B 168 SB-168 5889	B 166 SB-166	B 564 SB-564 5887
ISO	NiCr22Co12Mo9	9722	6207		6208		6208	9724	

1) The VdTÜV-Wbl. does not cover strip produced by ThyssenKrupp VDM.

Table 1 – Designations and standards.

Chemical composition

	Ni	Cr	Fe	C	Mn	Si	Co	Cu	Mo	Ti	Al	P*	S	B
min.	44.5	20.0		0.05			10.0		8.0		0.8			
max.		24.0	3.0	0.15	1.0	1.0	15.0	0.5	10.0	0.6	1.5	0.012	0.015	0.006

Some compositional limits of other specifications may vary slightly

Table 2 – Chemical composition (wt.-%) according to ASTM (*Not specified in ASTM)

Physical properties

Density	8.4 g/cm ³	0.303 lb/in. ³
Melting range	1330 – 1380 °C	2430 – 2520 °F

Temperature (T)		Specific heat		Thermal conductivity		Electrical resistivity		Modulus of elasticity		Coefficient of thermal expansion between room temperature and T	
°C	°F	$\frac{\text{J}}{\text{kg}\cdot\text{K}}$	$\frac{\text{Btu}}{\text{lb}\cdot^{\circ}\text{F}}$	$\frac{\text{W}}{\text{m}\cdot\text{K}}$	$\frac{\text{Btu}\cdot\text{in.}}{\text{ft}^2\cdot\text{h}\cdot^{\circ}\text{F}}$	$\mu\Omega\cdot\text{cm}$	$\frac{\Omega\cdot\text{circ mil}}{\text{ft}}$	$\frac{\text{kN}}{\text{mm}^2}$	10 ³ ksi	$\frac{10^{-6}}{\text{K}}$	$\frac{10^{-6}}{^{\circ}\text{F}}$
20	68	420	0.100	13.4	94	122	734	212	30.7		
93	200		0.104		101		748		30.0		6.4
100	212	440		14.7		125		206		11.6	
200	392	465		16.3		126		200		12.6	
204	400		0.111		113		757		29.0		7.0
300	572	485		17.7		127		194		13.1	
316	600		0.117		125		764		28.0		7.4
400	752	515		19.3		128		188		13.6	
427	800		0.124		137		770		26.9		7.6
500	932	545		20.9		129		181		13.9	
538	1000		0.131		149		779		25.8		7.7
600	1112	565		22.5		131		173		14.0	
649	1200		0.137		161		793		24.6		8.0
700	1292	595		23.9		133		166		14.8	
760	1400		0.144		173		803		23.3		8.4
800	1472	615		25.5		134		157		15.4	
871	1600		0.150		185		808		21.9		8.7
900	1652	645		27.1		135		149		15.8	
982	1800		0.157		197		824		20.4		9.0
1000	1832	665		28.7		138		139		16.3	

Table 3 – Typical physical properties at room and elevated temperatures.

Nicrofer® 5520 Co – alloy 617

Mechanical properties

The following properties are applicable to Nicrofer 5520 Co in the solution-treated condition and the indicated size ranges. Specified properties of material outside these size ranges are subject to special enquiry.

Product	Dimensions		Testing direction	0.2 % Yield strength Rp0.2		1.0 % Yield strength Rp1.0		Tensile strength Rm		Elongation A ₅ %
	mm	inches		N/mm ²	ksi	N/mm ²	ksi	N/mm ²	ksi	
Sheet and strip	cr < 6	< 1/4	transverse	350	51	380	55	750	109	35
Plate	hr < 80	< 3	transverse	300	44	330	48	700	102	
Rod and bar	≤ 300	≤ 12	transverse	300	44	330	48	680	94	30
			longitudinal							35

cr = cold rolled, hr = hot rolled

Table 4 – Mechanical properties at room temperature; minimum values according to VdTÜV Data Sheet 485.

Hardness: surface hardness of solution-treated and machined forgings: approx. 200 HB30.

Temperature		0.2% Yield strength Rp0.2		1.0% Yield strength Rp1.0		Tensile strength Rm		Elongation A ₅ %
°C	°F	N/mm ²	ksi	N/mm ²	ksi	N/mm ²	ksi	
20	68	300	43.5	330	47.9	700	101.5	35
38	100	(290)	(42.1)	(315)	(45.7)	(680)	(98.6)	
100	212	270	39.1	300	43.5	650	94.3	
149	300	(250)	(36.3)	(285)	(41.3)	(640)	(92.8)	
200	392	230	33.4	260	37.7	620	89.9	
204	400	(230)	(33.4)	(260)	(37.7)	(620)	(89.9)	
300	572	220	31.9	250	36.3	600	87.0	
316	600	(218)	(31.6)	(245)	(35.5)	(595)	(86.3)	
400	752	210	30.5	240	34.8	570	82.7	
427	800	(208)	(30.2)	(235)	(34.1)	(560)	(81.2)	
500	932	200	29.0	225	32.6	540	78.3	
538	1000	(198)	(28.7)	(220)	(31.9)	(530)	(76.9)	
600	1112	190	27.6	210	30.5	510	74.0	
649	1200	(188)	(27.3)	(208)	(30.2)	(480)	(69.6)	
700	1292	185	26.8	205	29.7	400	58.0	
750	1382	180	26.1	200	29.0	340	49.3	
760	1400	(178)	(25.8)	(198)	(28.7)	(330)	(47.9)	

(xxx)= approximate values interpolated from graphs

Table 5 – Mechanical properties at elevated temperatures; minimum values according to VdTÜV Data Sheet 485.

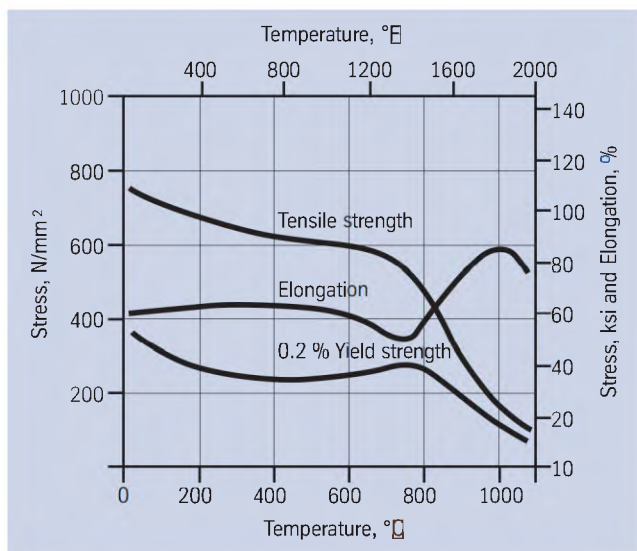

Fig. 1 – Typical short-time properties of solution-treated Nicrofer 5520 Co sheet and plate at elevated temperatures.

ISO V-notch impact toughness

Average values at RT: transverse ≥ 100 J/cm²
longitudinal ≥ 150 J/cm²

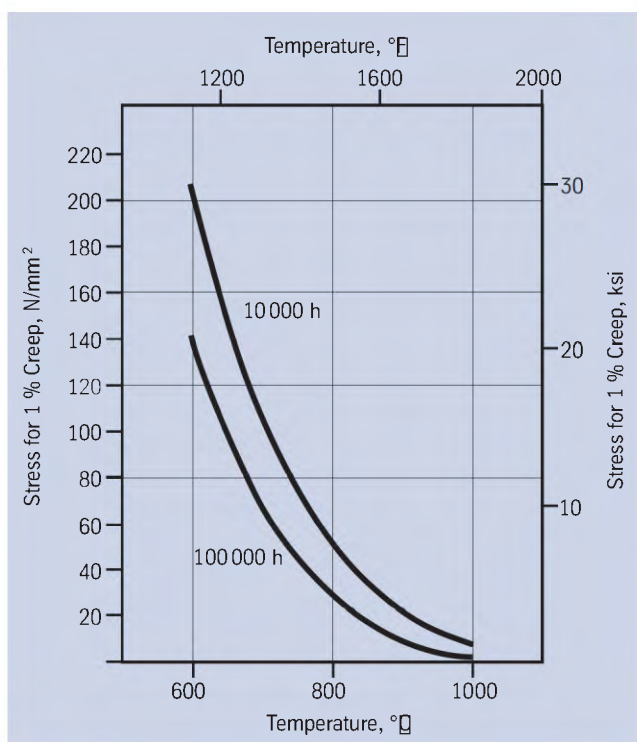

Fig. 2 – Typical stresses for 1% creep of solution-treated Nicrofer 5520 Co.

Metallurgical structure

Nicrofer 5520 Co has a face-centered cubic structure with good metallurgical stability. Its excellent high-temperature strength is achieved by solid-solution hardening. The alloy is not age-hardenable.

Relaxation cracking susceptibility

Nicrofer 5520 Co is susceptible to relaxation cracking if new solution-annealed and welded semi-fabricated products are exposed to service temperatures within the temperature range of 550-780 °C (1020-1436 °F) without a prior post-weld stabilizing heat treatment (PWHT) at 980 °C (1800 °F) for 3 hrs. The heating and cooling rates for such stabilizing heat treatments are not critical.

The subsequent service temperature range within which relaxation cracking may occur extends further to 500-780 °C (932-1436 °F), if products are reused which have already been in service and which have been repair-welded with matching alloy 617 consumables without a following stabilizing heat treatment at 980 °C (1800 °F) for 3 hrs.

Temperature		Stress to produce 1% creep			
		$R_p 1.0 \times 10^4$ h		$R_p 1.0 \times 10^5$ h	
°C	°F	N/mm ²	ksi	N/mm ²	ksi
600	1112	—	—	—	—
649	1202	148	21.5	97	14.1
700	1292	99	14.4	66	9.6
750	1382	68	9.9	44	6.4
800	1472	45	6.5	28	4.1
850	1562	29	4.2	18	2.6
900	1652	19	2.8	10	1.45
950	1742	11	1.6	4	0.58
1000	1832	5.5	0.8	1.0	0.15

Table 6 – Typical stresses to produce 1% creep in solution-treated Nicrofer 5520 Co.

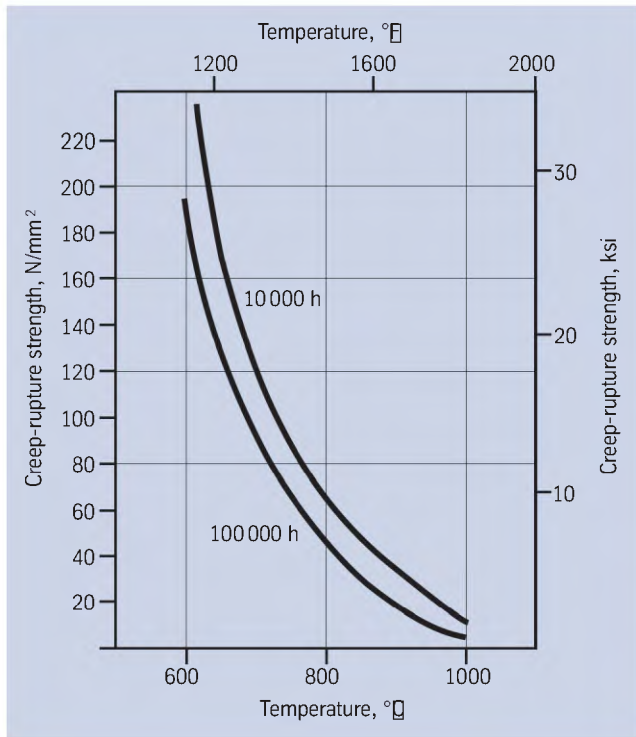

Fig. 3 – Typical creep-rupture strength of solution-treated Nicrofer 5520 Co.

Corrosion resistance

Nicrofer 5520 Co exhibits excellent resistance to hot corrosion such as oxidation and carburization under static and cyclic conditions up to temperatures of about 1100 °C (2000 °F). These properties, combined with outstanding mechanical properties, make this alloy especially suitable for high temperature applications.

Additionally the high contents of nickel, chromium and molybdenum contribute to the good overall corrosion resistance of Nicrofer 5520 Co in a variety of aggressive media.

Applications

Nicrofer 5520 Co is especially suitable where high temperatures and particularly high mechanical stresses are present. The alloy is recommended for service temperatures up to 1000 °C (1830 °F). Where weight savings are mandatory, Nicrofer 5520 Co is particularly effective as fabrication of thinwalled parts is possible.

Typical applications are:

- components for industrial and aircraft gas turbines, such as combustion cans, housings, turbine rings, and other parts exposed to high temperatures
- air heaters
- furnace muffles and radiant heater tubes
- high-temperature heat exchangers, valves and springs
- high-temperature gas-cooled nuclear reactors, such as the helium/helium intermediate heat exchanger for the high-temperature section of the nuclear process-heat prototype plant (PNP)

Temperature		Creep-rupture strength			
°C	°F	$R_m / 10^4 \text{ h}$		$R_m / 10^5 \text{ h}$	
		N/mm ²	ksi	N/mm ²	ksi
600	1112	260	37.7	190	27.6
650	1202	170	24.7	125	18.1
700	1292	123	17.8	95	13.8
750	1382	90	13.1	65	9.4
800	1472	65	9.4	43	6.2
850	1562	45	6.5	27	3.9
900	1652	30	4.4	16	2.3
950	1742	18	2.6	8.5	1.2
1000	1832	10	1.45	(4.5)	(0.65)

Table 7 – Typical creep-rupture strength of solution-treated Nicrofer 5520 Co.

- equipment for the chemical process industry (CPI), e. g. for the productions of styrene
- pigtails and furnace tubing in the petrochemical industry

Fabrication and heat treatment

Nicrofer 5520 Co can readily be hot and cold worked, fabricated and machined. Hot and cold working, however, require high-power machines owing to the strength of the material.

Heating

Workpieces must be clean and free from all kinds of contaminants before and during any heat treatment.

Nicrofer 5520 Co may become embrittled if heated in the presence of contaminants such as sulfur, phosphorus, lead and other low-melting-point metals. Sources of such contaminants include marking and temperature-indicating paints and crayons, lubricating grease and fluids, and fuels.

Fuels must be as low in sulfur as possible. Natural gas should contain less than 0.1 wt.-% sulfur. Fuel oils with a sulfur content not exceeding 0.5 wt.-% are suitable.

Due to their close control of temperature and freedom from contamination, thermal treatments in electric furnaces under vacuum or an inert gas atmosphere are to be preferred.

Treatments in air atmosphere and alternatively in gas-fired furnaces are acceptable though, if contaminants are at low levels so that a neutral or slightly oxidizing furnace atmosphere is attained. A furnace atmosphere fluctuating between oxidizing and reducing must be avoided as well as direct flame impingement on the metal.

Hot working

Due to the very high hot strength, considerable forces are required during hot forming.

Nicrofer 5520 Co may be hot worked in the temperature range 1200 to 950 °C (2190 to 1740 °F), followed by water quenching or rapid air cooling.

Heat treatment after hot working is recommended to obtain optimum properties.

For heating up workpieces should be charged into the furnace at maximum working temperature (solution-anneal temperature).

Cold working

Cold working should be carried out on annealed material. Nicrofer 5520 Co has a higher work-hardening rate than austenitic stainless steels. This should be taken into account when selecting forming equipment.

Interstage annealing may be necessary with high degrees of cold forming.

After cold reduction of more than 10 %, or more than 5 % for applications at temperatures above 900 °C (1650 °F) solution annealing is required before use.

Heat treatment

Solution heat treatment should be carried out in the temperature range 1150 to 1200 °C (2100 to 2190 °F). Water quenching is essential for maximum creep resistance. Below 1.5 mm (0.06 in.) thickness, rapid air cooling may be applied.

Stress-relief annealing may be performed at temperatures up to 870 °C (1600 °F).

For any thermal treatment the material should be charged into the furnace at maximum annealing temperature observing the precautions concerning cleanliness mentioned earlier under 'Heating'.

Descaling and pickling

High-temperature alloys develop a protective oxide layer in service. Pre-oxidation in air can produce increased corrosion resistance. Therefore on the basis of the end use the necessity of descaling should be checked.

Oxides of Nicrofer 5520 Co and discoloration adjacent to welds are more adherent than on stainless steels. Grinding with very fine abrasive belts or discs is recommended. Care should be taken to prevent tarnishing.

Before pickling in a nitric/hydrofluoric acid mixture, the surface oxide layer must be broken up by abrasive blasting or grinding or by pretreatment in a fused salt bath. Particular attention should be paid to the pickling time and temperature.

Machining

Nicrofer 5520 Co should preferably be machined in the solution-treated condition. The alloy's high work-hardening rate should be considered, i.e., only low surface cutting speeds with not too high a rate of feed should be selected. Tools should be engaged at all times.

An adequate depth of cut is important in order to cut below the previously formed work-hardened zone.

Welding

When welding nickel alloys, the following instructions should be adhered to:

Workplace

The workplace should be in a separate location, well away from areas where carbon steel fabrication takes place. Maximum cleanliness and avoidance of draughts are paramount.

Auxiliaries, clothing

Clean fine leather gloves and clean working clothes should be used.

Tools and machines

Tools used for nickel alloys and stainless steels must not be used for other materials. Brushes should be made of stainless materials.

Fabricating and working machinery such as shears, presses or rollers should be fitted with means (felt, cardboard, plastic sheeting) of avoiding contamination of the metal with ferrous particles, which can be pressed into the surface and thus lead to corrosion.

Cleaning

Cleaning of the base metal in the weld area (both sides) and of the filler metal (e.g. welding rod) should be carried out with ACETONE.

Trichlorethylene (TRI), perchlorethylene (PER) and carbon tetrachloride (TETRA) must not be used.

Edge preparation

This should preferably be done by mechanical means by turning, milling or planing; abrasive water jet or plasma cutting is also possible. However, in the latter case the cut edge (the face to be welded) must be finished off cleanly. Careful grinding without overheating is permissible.

Included angle

The different physical characteristics of nickel alloys and special stainless steels compared with carbon steel generally manifest themselves in a lower thermal conductivity and a higher rate of thermal expansion. This should be allowed for by means of, among other things, wider root gaps or openings (1-3 mm), while larger included angles (60-70 °), as shown in Fig. 4, should be used for individual butt joints owing to the viscous nature of the molten weld metal and to counteract the pronounced shrinkage tendency.

Striking of the arc

The arc should only be struck in the weld area, i.e., on the faces to be welded or on a run-out piece. Striking marks lead to corrosion.

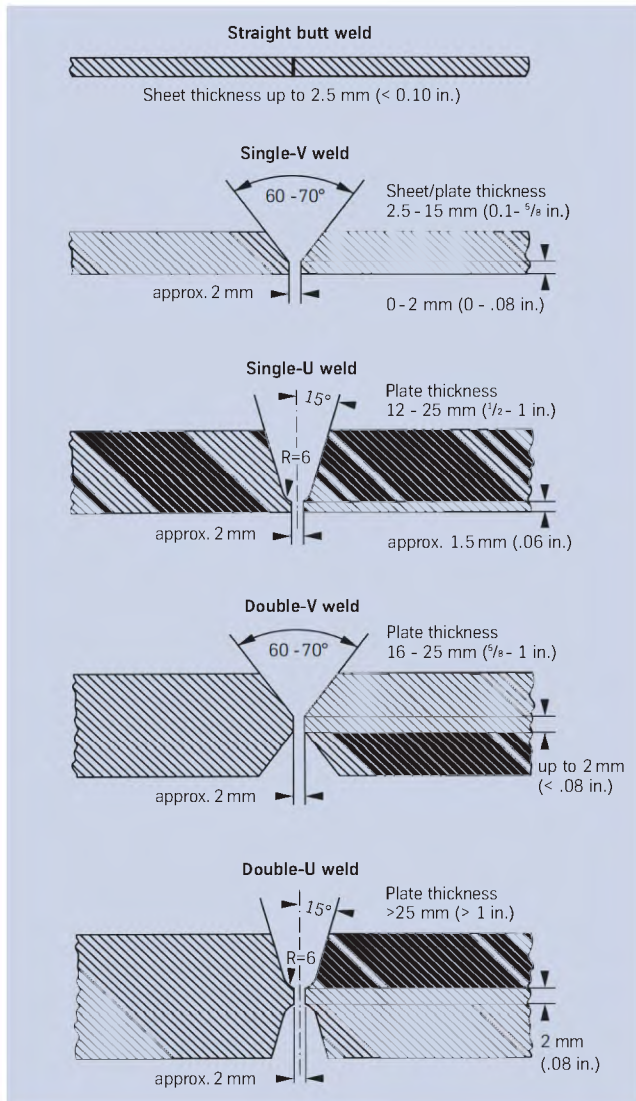

Fig. 4 – Edge preparation for welding of nickel alloys and special stainless steels.

Welding process

Nicrofer 5520 Co can be joined to itself and to many other metals by conventional welding processes. These include GTAW (TIG), GMAW (MIG/MAG), plasma arc, electron beam welding and SMAW (MMA). Pulsed arc welding is the preferred technique.

For welding, Nicrofer 5520 Co should be in the annealed condition and be free from scale, grease and markings. When welding the root, care should be taken to achieve best-quality root backing (argon 99.99), so that the weld is free from oxides after welding the root. Any heat tint should be removed preferably by brushing with a stainless steel wire brush while the weld metal is still hot.

Filler metal

For the gas-shielded welding processes, filler metal with the same composition as the base metal is recommended:

Bare electrodes:

Nicrofer S 5520 - FM 617 (W-Nr. 2.4627)
 UNS N06617
 AWS A5.14: ERNiCrCoMo-1
 DIN EN ISO 18274: S Ni 6617 (NiCr22Co12Mo)

Covered electrodes:

W.-Nr. 2.4628
 UNS W86117
 AWS A5.11: ENiCrCoMo-1
 DIN EN ISO 14172: E Ni 6617 (NiCr22Co12Mo)

Welding parameters and influences

(heat input)

Care should be taken that the work is performed with a deliberately chosen, low heat input as indicated in Table 9 by way of example. Use of the stringer bead technique should be aimed at. Interpass temperature should be kept below 120 °C (250 °F).

The welding parameters should be monitored as a matter of principle.

The heat input Q may be calculated as follows:

$$Q = \frac{U \times I \times 60}{v \times 1000} \text{ (kJ/cm)}$$

U = arc voltage, volts

I = welding current, amps

v = welding speed, cm/min.

Consultation with ThyssenKrupp VDM's Welding Laboratory is recommended.

Postweld treatment

(brushing, pickling and thermal treatments)

Brushing with a stainless steel wire brush immediately after welding, i.e., while the metal is still hot, generally results in removal of heat tint and produces the desired surface condition without additional pickling.

Pickling, if required or prescribed, however, would generally be the last operation performed on the weldment. Also refer to the information on 'Descaling and pickling'.

Neither pre- nor postweld thermal treatments are normally required.

However, to eliminate the risk of relaxation cracking of new solution-annealed and welded semi-fabricated products subsequently in use as stress-bearing components at service temperatures of 550-780 °C (1020-1436 °F) the stabilization annealing recommendations given under 'Relaxation cracking susceptibility' should be adhered to.

Such a stabilizing heat treatment should also be carried out on products which had already been in service and which have been repair-welded with matching alloy 617 consumables before they are returned into service at the extended temperature range of 500-780 °C (932 °F-1436 °F).

Sheet/ plate thick- ness mm	Welding process	Filler metal		Welding parameters				Welding speed cm/min.	Shielding gas Type & rate l/min.	Plasma- gas Type & rate l/min.
		diameter mm	speed m/min.	Root pass		Intermediate and final passes				
				I A	U V	I A	U V			
3.0	Manual GTAW	2.0		90	10	110 – 120	11	approx. 15	Ar W3 ¹⁾ 8 – 10	
6.0	Manual GTAW	2.0 – 2.4		100 – 110	10	120 – 140	12	14 – 16	Ar W3 ¹⁾ 8 – 10	
8.0	Manual GTAW	2.4		100 – 110	11	130 – 140	12	14 – 16	Ar W3 ¹⁾ 8 – 10	
10.0	Manual GTAW	2.4		100 – 110	11	130 – 140	12	14 – 16	Ar W3 ¹⁾ 8 – 10	
3.0	Autom. GTAW	1.2	approx. 1.2	Manual GTAW		150	11	25	Ar W3 ¹⁾ 12 – 14	
5.0	Autom. GTAW	1.2	approx. 1.4	Manual GTAW		180	12	25	Ar W3 ¹⁾ 12 – 14	
2.0	Hot wire GTAW	1.0				180	11	80	Ar W3 ¹⁾ 12 – 14	
10.0	Hot wire GTAW	1.2		Manual GTAW		220	12	40	Ar W3 ¹⁾ 12 – 14	
4.0	Plasma arc	1.2	approx. 1.0	approx. 180	25			30	Ar W3 ¹⁾ 30	Ar 4.6 3.0
6.0	Plasma arc	1.2	approx. 1.0	200 – 220	26			26	Ar W3 ¹⁾ 30	Ar 4.6 3.5
8.0	GMAW (MIG/MAG ²⁾)	1.0	6 – 7	Manual GTAW		130 – 140	23 – 27	24 – 30	Ar 4.6 ²⁾ 18	
10.0	GMAW (MIG/MAG ²⁾)	1.2	6 – 7	Manual GTAW		130 – 150	23 – 27	25 – 30	Ar 4.6 ²⁾ 18	
6.0	SMAW (MMA)	2.5		40 – 70	approx. 21	40 – 70	approx. 21			
8.0	SMAW (MMA)	2.5 – 3.25		40 – 70	approx. 21	70 – 100	approx. 22			
16.0	SMAW (MMA)	4,0				90 – 130	approx. 22			

¹⁾ Argon or argon + max. 3% hydrogen

²⁾ For MAG welding the use of the multi-component shielding gas Cronigon He30S, for example, is recommended.

In all gas-shielded welding operations, ensure adequate back shielding.

Figures are for guidance only and are intended to facilitate setting of the welding machines.

Table 8 – Welding parameters (guide values).

Welding process	Heat input per unit length kJ/cm	Welding process	Heat input per unit length kJ/cm
GTAW, manual, fully mechanised	max. 8	GMAW, MIG/MAG, manual, fully mechanised	max. 8
Hot wire GTAW	max. 6	SMAW, manual metal arc (MMA)	max. 7
Plasma arc	max. 10		

Table 9 – Heat input per unit length (guide values).

Availability

Nicrofer 5520 Co is available in the following standard product forms:

Sheet & plate

(for cut-to-length availability, refer to strip)

Conditions:

hot or cold rolled (hr, cr), thermally treated and pickled

Thickness mm	hr/cr	Width ¹⁾ mm	Length ¹⁾ mm
1.10 – < 1.50	cr	2000	8000
1.50 – < 3.00	cr	2500	8000
3.00 – < 7.50	cr/hr	2500	8000
7.50 – ≤ 25.00	hr	2500	8000 ²⁾
> 25.00 ¹⁾	hr	2500 ²⁾	8000 ²⁾

inches		inches	inches
0.043 – < 0.060	cr	80	320
0.060 – < 0.120	cr	100	320
0.120 – < 0.300	cr/hr	100	320
0.300 – ≤ 1.000	hr	100	320 ²⁾
> 1.000 ¹⁾	hr	100 ²⁾	320 ²⁾

¹⁾ other sizes subject to special enquiry

²⁾ depending on piece weight

Discs and rings

Conditions:

Available up to a maximum piece weight of 6 t for discs and 3 t for rings in accordance to drawings and technical feasibility.“

Rod & bar and billet

Conditions:

forged, rolled, drawn, thermally treated, pickled, machined, peeled or ground

Product	Forged ¹⁾ mm	Rolled ¹⁾ mm	Drawn ¹⁾ mm
Rod (o. d.)	≤ 500	12 – 100	12 – 50
Bar, square (a)	40 – 500	15 – 280	not standard
Bar, flat (a x b)	(40 – 80) x (200 – 500)	(5 – 20) x (120 – 500)	(10 – 20) x (30 – 80)
Bar, hexagonal (s)	40 – 80	subject to enquiry	

	inches	inches	inches
Rod (o. d.)	≤ 20	¹ / ₂ – 4	¹ / ₂ – 2
Bar, square (a)	1 ⁵ / ₈ – 20	¹⁰ / ₁₆ – 11	not standard
Bar, flat (a x b)	(1 ⁵ / ₈ – 3 ¹ / ₈) x (8 – 20)	(³ / ₁₆ – ³ / ₄) x (4 ³ / ₄ – 20)	(³ / ₈ – ³ / ₄) x (1 ¹ / ₄ – 3 ¹ / ₈)
Bar, hexagonal (s)	1 ⁵ / ₈ – 3 ¹ / ₈	subject to enquiry	

¹⁾ other sizes and conditions subject to special enquiry

Strip¹⁾

Conditions:

cold rolled, thermally treated and pickled or bright annealed²⁾.

Thickness mm	Width ³⁾ mm	Coil I. D. mm			
0.02 – ≤ 0.10	4 – 200 (700) ⁴⁾	300	400		
> 0.10 – ≤ 0.20	4 – 350 (700) ⁴⁾	300	400	500	
> 0.20 – ≤ 0.25	4 – 700		400	500	600
> 0.25 – ≤ 0.60	6 – 700		400	500	600
> 0.60 – ≤ 1.0	8 – 700		400	500	600
> 1.0 – ≤ 2.0	15 – 700		400	500	600
> 2.0 – ≤ 3.0 ²⁾ – ≤ 3.5 ²⁾	25 – 700		400	500	600

inches	inches	inches			
0.0008 – ≤ 0.004	0.16 – 8(28) ⁴⁾	12	16		
> 0.004 – ≤ 0.008	0.16 – 14(28) ⁴⁾	12	16	20	
> 0.008 – ≤ 0.010	0.16 – 28		16	20	24
> 0.010 – ≤ 0.024	0.24 – 28		16	20	24
> 0.024 – ≤ 0.040	0.32 – 28		16	20	24
> 0.040 – ≤ 0.080	0.60 – 28		16	20	24
> 0.080 – ≤ 0.120 ²⁾ – ≤ 0.140 ²⁾	1.0 – 28		16	20	24

¹⁾ Cut-to-length available in lengths from 250 to 4000 mm (10 to 158 in.)

²⁾ Maximum thickness: bright annealed - 3 mm (0.120 in.),
cold rolled only - 3.5 mm (0.140 in.)

³⁾ Wider widths subject to special enquiry

⁴⁾ Wider widths up to 700 mm (28 in.) subject to special enquiry

Wire

Conditions:

bright drawn, ¹/₄ hard to hard,
bright annealed

Dimensions:

0.1 – 12.0 mm (0.004 – 0.47 in.) diameter,
in coils, pay-off packs, on spools and spiders

Welding filler metals

Suitable welding rods, wire, strip electrodes and electrode core wire are available in all standard sizes.

Seamless tube and pipe

Using ThyssenKrupp VDM cast materials seamless tubes and pipes are produced and available from DMV STAINLESS SAS, Tour Neptune, F-92086 Paris, La Défense Cedex (Tel: +33-1-4796 8140; Fax.: +33-1-4796 8141). E-mail: dmv-hq@dmv-stainless.com).

Welded tube and pipe

Welded tubes and pipes are obtainable from qualified manufacturers using ThyssenKrupp VDM semi-fabricated products.

Technical publications

The following publications concerning Nicrofer 5520 Co may be obtained from ThyssenKrupp VDM GmbH:

U.Brill:

Korrosion von Nickel, Cobalt und Nickel- und Cobalt-Basislegierungen;
Reprint of Korrosion und Korrosionsschutz, 1992.

U.Brill, M. Rockel:

High-temperature alloys from Krupp VDM for industrial engineering; VDM-Report No. 25, 2000.

U. Heubner, J.Klöwer et al.:

Nickel alloys and high-alloy special stainless steels;
expert Verlag, 3rd revised edition, 2003.
ISBN 3-8169-2195-7

The information contained in this data sheet is based on results of research and development work available at the time of printing and does not provide any guarantee of particular characteristics or fit. ThyssenKrupp VDM reserves the right to make changes without notice. The data sheet has been compiled to the best knowledge of ThyssenKrupp VDM and is given without any liability on the part of ThyssenKrupp VDM. ThyssenKrupp VDM is only liable according to the terms of the sales contract and in particular to the General Conditions of Sales in case of any delivery from ThyssenKrupp VDM.

As updates of data sheets are not automatically send out, when issued, ThyssenKrupp VDM recommends to request the latest edition of required data sheets either by phone +49 (0) 23 92 55-25 88, by fax +49 (0) 23 92 55-25 96 or by E-mail under info@tk-vdm.thyssenkrupp.com.

Current issues of brochures and data sheets are also available in the Internet under www.thyssenkruppvdm.de

January 2005 Edition.

This edition supersedes material data sheet no. 4019, dated June 1994

The logo for Nicrofer is located in the top right corner. It features a dark blue horizontal bar at the top. Below this bar, the word "Nicrofer" is written in a light blue, sans-serif font, followed by a registered trademark symbol (®). Below "Nicrofer", there is a large, bold, dark blue hyphen followed by the letters "al" in a similar font, suggesting the word "Alloy".

Nicrofer®

ThyssenKrupp VDM GmbH

Plettenberger Strasse 2

58791 Werdohl

P.O. Box 18 20

58778 Werdohl

Germany

Phone: +49 (23 92) 55-0

Fax: +49 (23 92) 55-22 17

E-Mail: info@tk-vdm.thyssenkrupp.com

www.thyssenkruppvdm.com

QUEENSLAND AGENT:

Isolthermics Australia Pty Ltd

Phone: 07 3245 5561

Fax: 07 3245 4753

Email: info@isolthermics.com.au

Web: www.isolthermics.com.au